

# **Hi-Q™ Series HF Mobile Antennas**

## **Instruction Manual**

**Charles M. Gyenes W6HIQ,  
(VE7BOC/W6, HA5CMG, VA7HIQ)**

---

# **Hi-Q™ Series HF Mobile Antennas: Instruction Manual**

Charles M. Gyenes W6HIQ, (VE7BOC/W6, HA5CMG, VA7HIQ)

Copyright © 2007-2008

Covered by one or more US Patent numbers: 6,275.195 B1, 6,496.154 B2

Ordering and acceptance of this Hi-Q™ antenna does not constitute a license or agreement to reproduce, manufacture, re-engineer, or copy it in any form. Hi-Q™ Antennas hold all patents and trade marks. Patent infringements will be vigorously challenged!

---

---

---

---

# Table of Contents

1. Introduction .....	1
What this document covers .....	2
What this document does not cover .....	2
2. Optional Accessories .....	3
3. Specifications .....	6
Bands .....	6
Power limits .....	6
Hookups .....	6
Motor .....	6
Whips Not Included .....	7
Matching .....	7
Capacitive matching (preferred method) .....	8
Shunt coils .....	8
Capacity hats .....	9
Radials (For fixed installation) .....	9
Turns counting .....	10
Antenna controllers .....	10
Special notes for Hi-Q™-5/160 Antenna users .....	10
4. Installation .....	11
Motor Control Switch .....	14
Ferrites .....	15
Tractor-trailers .....	15
Other vehicles .....	16
5. Operation .....	17
Initial tuneup .....	17
Tuning the antenna .....	17
6. Troubleshooting .....	19
Can't get a good match .....	19
Motor noise in receiver .....	19
7. Care and Feeding .....	20
Keep the coil clean! .....	20
Periodic Maintenance .....	20
8. Hi-Q™ Antenna Guarantee .....	21
9. Contact Info .....	22
A. Tune-A-Dipole Instructions .....	23
B. Photo Galary .....	25

---

## List of Tables

2.1. Hi-Q™ Accessories .....	4
3.1. The natural impedance values for the Hi-Q Series of HF Mobile Antennas are: .....	8

---

## Chapter 1. Introduction

Thank you for your purchase!

The Hi-Q Antennas™ Mission Statement: Force the competitors to produce a better quality and better performing antenna by leading the way!

The new, improved, Hi-Q Antennas™ by W6HIQ / VE7BOC / HA5CMG / VA7HIQ are the latest, state-of-the-art, 6th generation design. High Q and high radiation efficiency are provided by computer design and proven by extensive testing both in the lab and on the air. Hi-Q Antennas™ are constructed from all Mil-Spec materials on CNC machine tools. Most amateur models are based on military designs.

The Hi-Q™ antenna series is designed for mobile installation. It is a center loaded HF mobile antenna. The Hi-Q Antennas™ design is *not* a cheap copy of the original Don Johnson screwdriver antenna. These Hi-Q Antennas™ products have the highest radiation efficiency and the highest level of quality in an HF Mobile antenna *ever* designed and manufactured. They are covered by one or more of the following patents: US 6,275.195 B1 and US 6,496.154 B2. For a more in-depth comparison between the Hi-Q Antennas™ design and screwdriver-type designs, [click here](#)<sup>1</sup>.

The NEW Hi-Q™ TAD™ (Tune-A-Dipole™) and the latest NVIS series of HF dipole antennas offers 2.1 dB gain and directivity compared to the mobile vertical and it can be used in either horizontal or vertical configuration. NVIS is a *very low noise* antenna. The beauty of it that you can feed it with 52-ohm coax cable, in some cases without any matching device and *no need* for radials or counterpoise! See [photos on the website](#)<sup>2</sup>. The NVIS antenna (TAD™ used on a low tripod) will give you excellent short range communication with low power at a very low noise level.

The *new* Hi-Q™ NVIS/COMBI antenna offers the best of both *short* and *long* range communication. Please visit the Hi-Q™ Military web site for details.

We measure our antenna performance with high-end test equipment, to back up what we advertise! One *test* is worth a thousand so-called expert *opinions*. [Click Here](#)<sup>3</sup> to see more about the [Hi-Q™ Test Lab](#)<sup>4</sup>.

Be sure to check the [latest news page](#)<sup>5</sup> for new product announcements, hamfest schedules, etc. You may also wish to [subscribe to our mailing list](#)<sup>6</sup> to ask questions and get advice from other owners of Hi-Q Antennas™ products. If you have any questions, please don't hesitate to contact me. You may also get answers to many common questions by reading this Hi-Q Antennas™ installation manual, and by visiting the [ARRL Automotive RFI web site](#)<sup>7</sup>.

Hi-Q™ products are covered by one or more US Patent numbers: 6,275.195 B1, 6,496.154 B2

Ordering and acceptance of this Hi-Q™ antenna does not constitute a license or agreement to reproduce, manufacture, re-engineer, or copy it in any form. Hi-Q™ Antennas holds all patents and trade marks. All rights reserved.

### Warning

Patent infringements will be vigorously challenged!

Enjoy the use of your new Hi-Q™ antenna.

---

<sup>1</sup> <http://hiqantennas.com/compare.htm>

<sup>2</sup> <http://www.hiqantennas.com/photos>

<sup>3</sup> <http://www.hiqantennas.com/test-lab.htm>

<sup>4</sup> <http://www.hiqantennas.com/test-lab.htm>

<sup>5</sup> <http://www.hiqantennas.com/news.htm>

<sup>6</sup> <http://www.hiqantennas.com/mailling-list.html>

<sup>7</sup> <http://www.arrl.org/tis/info/rficar.html>

For a lot more information and photos be sure to browse my entire [website](#)<sup>8</sup>.

73 - Charlie Gyenes W6HIQ / VE7BOC / HA5CMG

## What this document covers

This document is designed to guide you through a basic mobile installation of your new antenna system. It covers mounting the antenna, connecting a control switch, and matching the impedance of the antenna.

## What this document does not cover

This document does not cover basic radio theory. This document does not describe how to install your mobile HF radio. The [ARRL](#)<sup>9</sup> publishes several good books on these topics. This document does not describe any automatic antenna controllers. Please *do not* contact Hi-Q Antennas™ for technical support regarding 3rd party automatic controllers.

*New from Hi-Q™: MC-3 digital DC motor controller, and MC-4 stepper motor controller.*

---

<sup>8</sup> <http://www.hiqantennas.com>

<sup>9</sup> <http://www.arrl.org>

---

## Chapter 2. Optional Accessories

**“GQD” (Giant Quick Disconnect).** A 2” diameter double bayonet quick-disconnect to remove the *whole* antenna in just seconds. Machined out of a single piece of stainless steel, we highly recommend this accessory.

**Whip Quick Disconnect.** Standard Whip Quick Disconnect (WQD) for the whip, new design, all brass, silver-plated whip quick disconnect. This two-piece unit speeds whip changes.

**Whip BASE Connector.** Use this silver plated brass connector after cutting a stainless steel whip to the right length for your installation. Securely holds your whip in place.

**Second antenna purchase.** \$50 discount or FREE GQD, a \$65 value.

**Mast-mount Insulator.** Insulating sleeve for mast used for base station mounting, please specify the mast inside diameter.

**Capacitance Hat.** Increase the radiation efficiency of your Hi-Q™ Antenna. Cap Hat goes between the top of the coil, 1’ extension and the whip...fewer turns...L-o-u-d-e-r signal! Replaceable lobes. Requires 1 or 2 foot long extension rod.



**Table 2.1. Hi-Q™ Accessories**

<b>Product</b>	<b>Description</b>	<b>Price</b>
Accessory package A	1 Whip-quick-disconnect and 2 clip on ferrites	
Accessory package B	WQD, 2 clip-on ferrites, cap-hat, aluminum GQD	
GQD	Giant Quick Disconnect -- Stainless steel	\$75.00
GQD-light	Giant Quick Disconnect -- nickel plated aluminum	\$65.00
GQD Installation Kit	Only needed with 2nd GQD	\$15.00
Base Fold Over	0-90 degrees	\$55.00
Mast extension	1 foot, stainless steel with 3/8-24 interconnect stud	\$40.00
Mast extension	2 foot, stainless steel with 3/8-24 interconnect stud	\$50.00
WQD	Whip Quick Disconnect	\$25.00
WQD Top	The upper part only, for use with extra whips	\$15.00
WQD with fold-over		\$35.00
Whip base connector		\$10.00
Polycarbonate or Delrin base insulation wafers with bolt		\$15.00
Reed switch		\$10
MB-8 -- Mounting Bracket	1/2 x 2 x 8" pre-drilled for insulating washers	\$25.00
SUV Mounting Bracket	Special Mercedes or other SUV mounting unit	\$250.00
Mast-mount Insulator		\$20.00
Capacitance Hat		\$35.00
Single lobe Cap Hat	Adjustable height, fits standard whips	\$15.00
EB-4 -- Spherical Capacitance Hat		\$75.00
EB-8 -- Spherical Capacitance Hat		\$85.00
Corona balls	For heavy duty whips	\$10.00

Prices subject to change. For current prices please visit the HI-Q™ website or call. All prices FOB at the Hi-Q™ factory. Shipping and handling charges apply. See our web site for details, photos and ordering/shipping instructions. Feel free to contact HI-Q™ at: <w6hiq@hiqantennas.com>, or <sales@hiqantennas.com>

Order online 24-7 365 at <http://www.hiqantennas.com><sup>1</sup>

Telephone: 951-674-4862

Fax: 951-245-2031

OPEN from 8-5 Mo-Fr.

## **Important**

Please do not call outside of working hours!

---

<sup>1</sup> <http://hiqantennas.com/order.htm>

---

## Chapter 3. Specifications

Compare Quality and Performance!!! Why buy a *contraption* when you can have the *best* in any one of the Hi-Q™ designs. The loading coil is housed in custom extruded G.E. Lexan™ (Polycarbonate tubing) with extra doses of UV protection and bronze coloring (military models are all black). Coil wire is #12 gauge enamel coated to take the amplifier power, up to SSB legal limit.

No moving parts outside, No length changes. The contactor (RF coupler) travels within the sealed coil housing, kept out of the harsh environment. Silver plated Beryllium copper finger stock is in contact with two turns of the coil, 720 degrees, at all times. The RF De-Coupler contacts the silver plated tubing that is activated by a stainless steel threaded lead screw for tuning.

### Bands

All Hi-Q™ antennas tune continuously from 10m through 80m. Certain models will tune down to 160m.

6m operation is possible when the antenna length is approximately 60", or when the antenna is tuned to an odd harmonic wavelength.

### Power limits

All Hi-Q™ models are rated for full legal limit 1500 watts PEP on SSB.

#### Warning

Reduce power when operating on wintry salted roads! Salt spray and road crud can build up a conductive coating on your coil housing which may cause arcing along the surface. This damage is not covered by your guarantee!

### Hookups

Motor wires: Red and black. 12VDC (24VDC for military units)

Pulse wires: White or black. Connected to normally open reed switch, closes twice per revolution. For use with turns-counting antenna controller.

### Motor

High-quality, aircraft-type 12 VDC planetary gear head motor.

No resistor is needed to drop the line voltage.

Most users will install a momentary double-pole double-throw (DPDT) switch to actuate the motor. Motor reversal is achieved by reversing the polarity of the motor voltage. A simple schematic is given for how to wire the switch.

A Self-Resetting circuit breaker is installed at the motor. This breaker will "trip" out if your antenna contactor tops/bottoms out for too long. They will reset themselves within just a few moments once current is removed. Be sure to reverse the motor immediately and move the contactor off of bottom or top.

#### Note

Models manufactured before July 1, 2002, may require user to install the RXE-050 circuit breaker. Please request them from Hi-Q™ Antennas. All antennas sold since then have the circuit breaker installed internally from the factory.

## Whips Not Included

*Not included* are the stainless steel whip(s) you'll need. These are available from Radio Shack and other suppliers. You may want two of them to get the best antenna performance. However, a single 5-foot whip is a good compromise. If you want maximum performance, cut the whip as long as possible, but keep safety in mind. Never exceed 13'6" maximum height without bending or restraining the whip. You may want to order several of our Whip Base Adapters that turn the resultant whips into beautiful extensions for your Hi-Q™ antenna. If you have purchased the Hi-Q™-4/80 antenna then one 5' or even shorter whip will serve you fine, but for the greatest radiation Efficiency on 80/40 use the longest whip you have with a CapHat.

The whip can be as short as 2 feet for excellent 10 through 40-meter operation and 7 feet or longer for the lower bands. Again a CapHat will greatly reduce the whip length and increase the Radiation Efficiency! A Whip Quick Disconnect (WQD) is recommended for the whips. We manufacture an all-brass, silver-plated WQD — see website "Accessories" section. The coil's top cap is aluminum and the 3/8-24 thread can be worn out by changing whips too often. *New*: WQD with FOLD-OVER top!

*New*: Whip quick disconnect with *fold-over* top!

### Note

All Hi-Q™ antennas are now shipped with a whip quick disconnect pre-installed.

### Warning

The *new* WQD's are HEX. If it is too tight, use *two* 7/8 wrenches, *do not* unscrew the male part from the coil top!

Do not use a stainless steel split (lock) washer between the whip and the top of the coil. If you feel you must use a washer, use a soft, copper washer (a 3/8 lug with wire end cut off will do nicely).

### Warning

When disconnecting the WQD, do not unscrew the top coil cap! This will ruin the coil assembly. New WQDs are hex and you may use a wrench. Older WQDs have a 3/16" diameter hole on the male part; use this to SUPPORT IT WHILE UNSCREWING the whip or if the whip got too tight on the WQD FEMALE.

The recommended whip length is 8 feet for optimum performance on 40 & 80 M. However, 7'6" seems to work very well also, as safe clearance issues should ALWAYS take precedence. For operation on 6 to 40 meters, a 2-foot or shorter whip seems to work best. It is possible to find a resonant point for 6 & 10 meter bands at 5/8, 3/4, or even multiple wavelength positions on the coil with the longer whip. Feel free to experiment with various whip lengths, capacity hats and contactor positions. For *maximum* radiation efficiency on 40m, 80m, and 160m, you should use a capacitance hat with an extension rod.

## Matching

Although the Hi-Q™ is nominally a resonant antenna, additional impedance matching of some form is usually required due to capacitive coupling to the car body. With no impedance matching the nominal Hi-Q™ SWR is approximately 1.5:1 on 10m, 12m, 15m, 17m, and 20m, 1.7:1 on 40m, 2.4:1 on 80m, and 3:1 on 160m.

Hi-Q™ recommends the MFJ-909 or MFJ-910 Mobile Antenna Matcher. We are slowly getting away from the shunt coil, since the MFJ-910 and the MFJ-909 do an excellent job at a very low cost.

For the 40 and 80 Meter bands, you **MUST** use a matching device to bring the feed point impedance close a nominal 52 ohms. This can be easily achieved with the supplied shunt coil.

**Table 3.1. The natural impedance values for the Hi-Q Series of HF Mobile Antennas are:**

	Hi-Q-2.5/80 @ 3.750 MHz is approx. 22 Ohms
Hi-Q-3/80 @ 3.750 MHz is approx. 18 Ohms	Hi-Q-4/80 @ 3.750 MHz is approx. 12 Ohms
Hi-Q-4/160 @ 1.850 MHz is approx. 10 Ohms	Hi-Q-5/80 @ 3,750 MHz is approx. 10 Ohms

### Capacitive matching (preferred method)

The new MFJ-910 or 909 HF Mobile Antenna Matcher does a good job on matching the antenna to the radio's 52 ohm impedance. It may be installed at the rig end, close to the operator's hand.

#### Note

You can use a shunt coil plus the MFJ-909 if you have lots of static electricity build up potential.

### Shunt coils

One end of the coil is attached to the antenna's feed point at the 9/16th bolt and the other end to goes to ground. However, before you permanently ground the coil, determine the best VSWR by simply shorting out turns of the shunt coil one-by-one until the VSWR reaches its lowest point. This is usually less than 1.5:1. Solder the ground tap at this point. You may want to test the tap at different points around the coil for fine tuning purposes.

It is recommended that you adjust the coil for minimum SWR on the lowest band of operation. This will be 80m for most users. It is usually possible to achieve a 1.1:1 match on 80m using a shunt coil. This will result in an approximately 1.4:1 match on 40m, which is an acceptable compromise. The match will improve on higher frequencies.

A shunt coil may be made using #12 or heavier bare copper wire, close-wound on a 1.25" to 1.5" mandrel, and then stretched slightly to create an air gap of approximately one half of the wire's diameter between the turns; just make sure coils aren't touching each other.

Typically the shunt coil best used right at the antenna base, one end to the 3/8-24 mounting bolt or to one of the three base support bolt and the PIGTAIL from ground to the 8th turn of the shunt coil. This will change up/down in number of turns.

The shunt coil may be installed at the mounting point as well (see page 9 of this guide). The shunt coil can be installed either at the base of the antenna at the 3/8-24 mounting bolt or by using a "T" type coax connector at any point in the cable within 2 feet of the antenna base. Simply add the shunt from the connector center to ground. Usually 7-10 turns of wire (1.5" diameter) and a small spread will do fine for 75/80 meters, and 4-8 turns for 40 meters. When operating on higher frequencies the RF will simply "look through" the shunt. (See the additional information enclosed on this.) If you'd rather, the shunt may be switched in and out with a good quality ceramic switch.

Another advantage to a shunt is that it provides a DC path to ground, adding a degree of protection to your equipment against damage from static discharge.

A shunt coil may be used in conjunction with an MFJ mobile matcher for absolute minimum SWR, although this is typically not necessary.

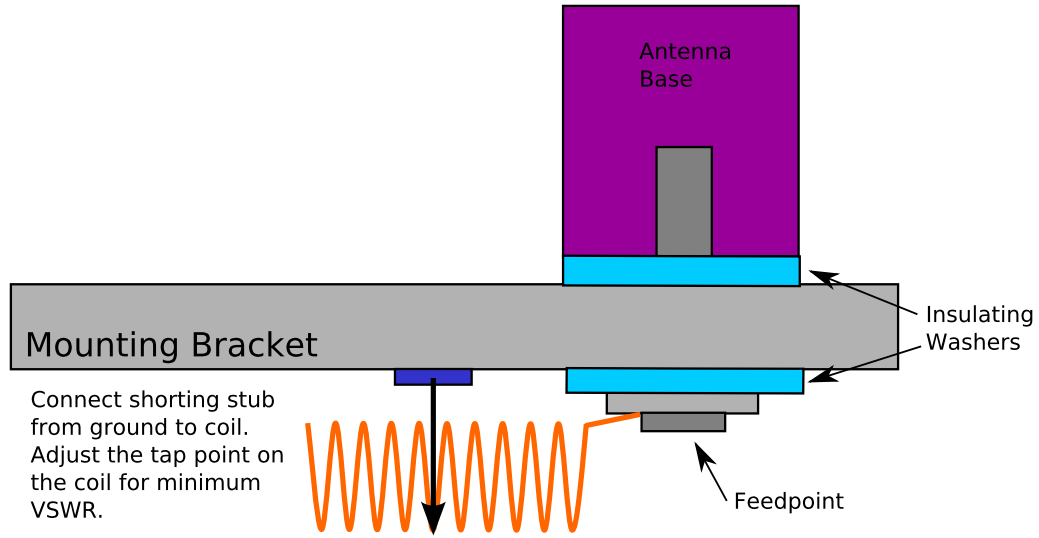

Shunt Coil Configuration

## Capacity hats

The CapHat *must* be raised at least 1 to 2 feet above the coil with an extension rod, available as an optional item. In some cases you may be able to keep a LOW profile with a 2' extension rod with and a CapHat *only* (no whip). This may cover 10-80 M with the same efficiency as if you have used a long whip with no capacity hat.

Check out the improvement you can get with the *new* EB-4 or -8 CapHats!

If you use a Capacity Hat with your Hi-Q™ antenna, you will find that the antenna is more efficient, uses fewer coil turns. The best location for the Cap Hat is one to two feet above the loading coil. Hi-Q™ sells extension rods. Please refer to the Accessories section.

### Warning

The Whip-Quick-Disconnect is mandatory if you use a CapHat with the Extension rod.

### Warning

DO NOT USE the LARGE 16&32" CapHats on the Hi-Q™-2.5 antennas.

### Warning

NOTE to Hi-Q™ -2.5 and -3 "S" model users: DO NOT USE LARGE CapHat or 102" whip, when you hit a tree or something you will damage the coil assembly (It will cost you \$125.00 for a new one!.)

## Radials (For fixed installation)

In some base station applications (attic, balcony, out a window, on a fence, or tripod installation) you may need to provide an adequate counterpoise by running several 0.2 to 0.25 wavelength wires out

from the base of the antenna. (See the ARRL Antenna Handbook for various counterpoise lengths and specifications.) The MFJ-909 Antenna Matcher or a simple antenna tuner will help.

## Turns counting

Most current production Hi-Q™ antennas have an internally mounted reed switch that is magnetically activated to close twice per motor output shaft revolution. This can be used to count the turns of the motor using a screwdriver antenna controller (Optionally available from Hi-Q™).

The controller is counting the revolution of the motor shaft, two pulses per revolution, or 20 TURNS per inch on Hi-Q™-2.5, -3 and -4. (Hi-Q™-5 is TWO pulses per turn and ¼-28 actuator shaft.)

### Note

Hi-Q™ antennas manufactured before September 2005 have an internal magnet, but do not have an internal reed switch. The reed switch is available as an accessory from Hi-Q™ and can be mounted externally. The magnet location can be found just above the motor with an ohmmeter and a reed switch. It is approx.. 2-1/2" from the 6/32 phillips-head screws that hold the motor in place.

## Antenna controllers

*New from Hi-Q™: MC-3 digital DC motor controller, and MC-4 stepper motor controller.*

The MFJ/Ameritron SDC-100, MFJ-1922, and MFJ-1924 controllers have been tested and they do work with Hi-Q™ antennas. However they have a high rate of failure. Hi-Q™ and Hi-Q™ antennas are not responsible for failed controllers. Please do not contact Hi-Q™ for technical support for using third-party antenna controllers, or in regards to a failed controller.

## Special notes for Hi-Q™-5/160 Antenna users

The Hi-Q™-5/160 antennas are designed to be used with the large 30" or new EB-8 capacity hats. Versions manufactured after 10/04 will resonate down to 1800 Kc, without a CapHat but only with a 102" whip.

Capacity hats must be installed at least one foot above the coil by means of an extension rod. Use a Radio Shack or similar 102" stainless steel whip on top of the Cap Hat. This may extend the tip of your antenna above the recommended 13'6" height limit. However, as the US Navy Antenna Test Site in Colorado suggests, you may *bend* the whip in an arc, or at a 45-degree angle, for an even *higher* radiation take off angle (NVIS). This method may also be used on the standard Hi-Q™ antennas for higher radiation efficiency with lower noise pick up, but shorter range due to the NVIS effect.

---

## Chapter 4. Installation

For optimal performance of your new Hi-Q™ antenna, we recommend that you elevate the feed point as high as is practical and safe.

### Warning

For safe highway over head clearance, be sure that your total antenna height does not exceed 13'6".

#### Procedure 4.1. Pre-installation Checklist

1. Carefully inspect antenna for damage during shipping.

As you can see, we have taken every precaution to make sure your new antenna arrives in factory perfect condition. If the parts box or tube is crushed, dented, or damaged in any way, please inform the carrier IMMEDIATELY.

Your antenna has been fully insured for shipping, but take time to inspect it carefully when it arrives. Keep the shipping tube for storing the antenna when not in use or for shipping should it become necessary to do so. Take digital pictures of any damage.

2. Verify the contents of your package. Every Hi-Q™ kit should include:
  - Hi-Q™ HF Antenna with coil assembly, lower mast and motor housing with 3/8-24 NF threaded mounting base
  - Installation Kit consisting of:
    - two polycarbonate insulator wafers
    - one (1) 3/8-24 bolt
    - several stainless steel washers
    - 3/8 lug for the coax cable center

Also check for any optional equipment you ordered. Optional equipment may be packaged with your antenna, separately, or pre-installed. If anything is missing, please contact Hi-Q™ immediately. Common accessories include:

- Giant Quick Disconnect and base
  - Whip Quick Disconnect and base
  - Pre-drilled MB-8 mounting bracket
  - Capacitance Hat
  - Digital Controller
  - Base Fold-over
3. The following tools are recommended for installation
    - 3/8 wrench



- Ring terminal crimping tool
  - Wire strippers
  - HF radio and SWR meter, or antenna analyzer
  - Soldering iron
4. The Following supplies are recommended for installation
- RG-8X Coaxial Cable
  - Lots of clip-on ferrites
  - 2 big yellow crimp-on ring terminals, to connect coax to antenna
  - crimp-on butt splices or some other means to splice the control wires
  - Momentary double-pole double-throw toggle switch
  - Solder
  - Electrical tape
  - Coax-seal or similar
  - Four conductor wire to power the motor and carry turn count pulses
  - Short sections of narrow gauge solid insulated wire for polarity switch

### **Procedure 4.2. Equipment Checkout**

It's recommended that you bench-test antenna motor, before you attempt to install it.

1. Set up 12v DC power supply. The motor draws about 500mA, so most any power supply should do.
2. The red and black wires are the motor control wires. The contactor is tuned to the *very top* for shipping. To move it down, connect the positive voltage supply to the *black* wire and the negative supply to the *red* wire. Observe that the motor moves the contactor *down* inside the coil.
3. Reverse the polarity to the motor and observe that the contactor moves up inside the coil.
4. Leave the contactor parked approximately in the middle of the coil.

### **Warning**

Do not run the contactor into the coil ends or damage may result.

### **Procedure 4.3. Installation Procedure**

1. Determine mounting location and install mounting bracket on vehicle.
2. Recommended: Use several ferrite chokes on the outside of the coaxial cable at both the antenna and radio ends, or you may also make 8 to 10 turn coils out of the coax. You may want to use a piece of heat shrink tubing over the whole assembly.
3. Crimp ring terminals to the center conductor and shield of the coaxial cable.

4. Connect coax outer braid to mounting bracket ground lug or other suitable chassis ground point.
5. Be sure to use copper braid for grounding straps to the vehicle chassis. RG-8 size coax cable braid makes excellent grounding straps.
6. The feed point can be either the 3/8 mounting bolt or ONE of the 3, 1/4-28 bolts for more convenient pick up. If you are using the 3/8 mounting bolt as your feed point, be sure to attach the coax ring terminal to it before mounting the antenna or quick disconnect base. The antenna must be insulated from the vehicle ground. Use the two supplied polycarbonate or Delrin insulating wafers.

### **Warning**

Be very certain that the mounting surface under these insulating wafers is perfectly flat. Some bumper hitches, especially the receiver type (Reese, U-Haul and others) have “punched” rather than drilled holes. Punching tends to leave a concave rim around the edge of the hole and when tightening the antenna mount, the concave shape will break the washers. Thin stainless steel shims should be used if this is the case. Otherwise, use our predrilled mobile mount (MB-10) to be sure that the mounting surface is flat.

### **Note**

Let us know if the mount you are using is thicker than 1/2” and we’ll supply you with a longer bolt.

7. If you have purchased the optional GQD (strongly recommended), install the base on your mounting bracket, using the supplied hardware. Otherwise install the antenna with the 3/8-24 bolt to the car’s mounting bracket. If you are using the 3/8 bolt as the feedpoint, don't forget to connect the coax! And don't forget about the insulating washers!
8. Hi-Q™-5/160 and Hi-Q™-5/80 users: Due to the large heavy coil and the additional stress it places on the mounting assemblies, it is strongly suggested to use additional means to support to the antenna. This can be in the form of a *non-conductive* bracket or guy-line attached just below the loading coil. This will stabilize the antenna and reduce the likelihood of damage to the mounting hardware.
9. Recommended: With each motor control lead make several turns around a ferrite clip-on choke or toroid core. These chokes should be as close to the base of the antenna and to the radio as possible. You may want to use a piece of heat shrink tubing over the whole assembly.
10. Splice your control wires to the leads coming out of the antenna base.

The Red/Black pair is for the motor, and the white or black pair is for the turns counting (pulse output).

11. Install switch or antenna controller at operator position.

Several 3rd party automatic screwdriver antenna controller products are on the market. Hi-Q™ does not endorse any of them. We recommend the Hi-Q™ digital DC controller, or a simple DPDT switch. Refer to Motor Control Switch section for more information.

*New from Hi-Q™: MC-3 digital DC motor controller, and MC-4 stepper motor controller.*

12. Install desired matching device.

Most installations require some form of impedance matching. Known to work are a capacitive match box like the MFJ mobile units, and a shunt coil. Please refer to the matching section for more information.

13. Attach whip and optional capacity hat with extension rod.
14. Coat antenna base mast and coil with Rain-X or automotive wax.
15. Proceed to Initial Tuneup section

### Important

Do NOT PLUG up the hole where the motor wires exit from the antenna base! Do NOT use RTV (silicone) or tape to seal this hole. Condensation moisture, if present, drains out at this hole.

## Motor Control Switch

Use a momentary, DPDT, center off switch to reverse the polarity of the motor. This switch is available at Radio Shack and other electronics dealers. To make the switch work in both directions "X" wires the contacts 1&2 to 5&6. Prior to soldering the wires, insulate both leads with shrink tubing or the insulation from some #20 wire to prevent a possible short circuit. Attach the 12VDC leads to the center two contacts on the switch. Now, attach the each motor lead to either the top or bottom set of contacts.

Toggle the switch in either direction and note which way the contactor moves. Solder all connections cleanly. Use your VOM to check all continuities. Orient your switch to reflect up/down when you mount it. You may also add a variable voltage control and speed-up the contactor motion when going from 20 meters to 80 meters for example.

### Warning

Antennas manufactured prior to January 2003 require a self resetting thermal circuit breaker to be installed inline with the motor leads. All antennas manufactured since January 2003 have this internally.

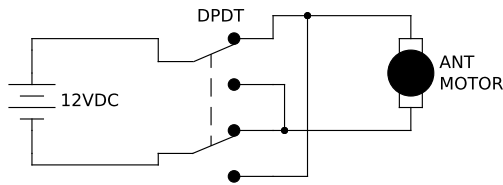

Switch Wiring Schematic

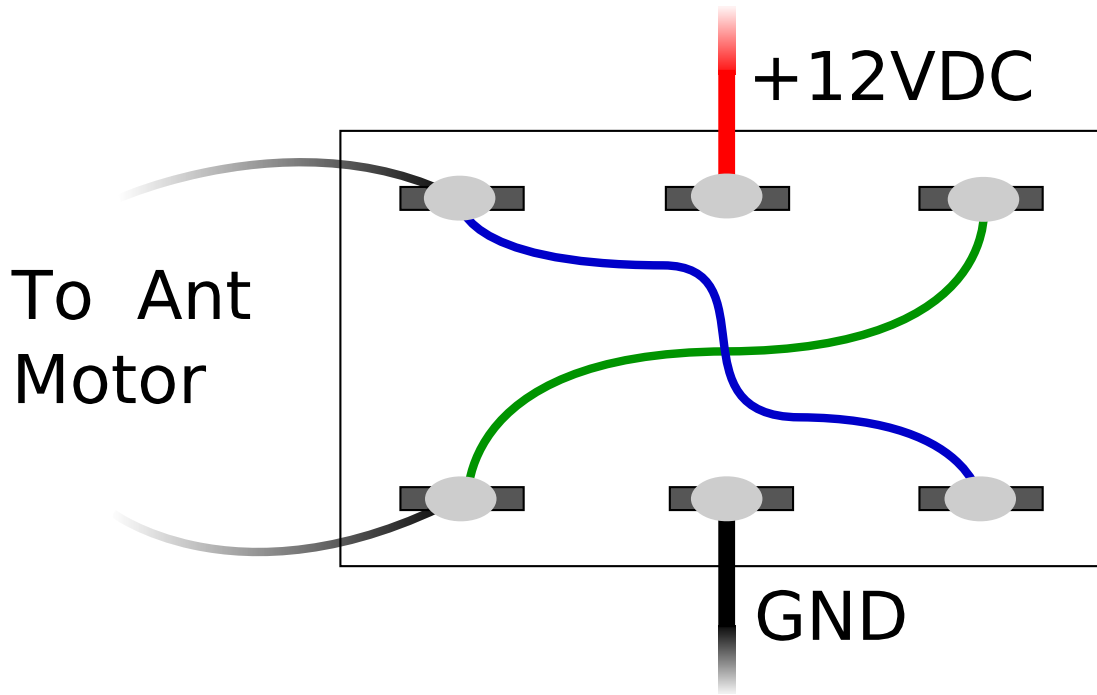

Switch Wiring Diagram

## Ferrites

HI-Q™ strongly recommends the use of ferrite chokes on both the coaxial cable and motor control lines, to choke common mode current. Ferrites should be installed at *both* ends of *both* cables, as close to the antenna, and as close to the radio as possible.

As an alternative to putting ferrites on the coaxial cable, you may make 8 to 10 turn coax coils at both the antenna and radio ends.

Ferrites are available as an option from Hi-Q™.

### Tip

Slip a piece of shrink tubing over the whole assembly to hold the ferrites together and for protection.

## Tractor-trailers

You will most likely want to install your NEW Hi-Q™ antenna on the driver side mirror arm. You can use a short extension rod and a CapHat with a very short whip.

### Note

Only the Hi-Q™ 4, 5 and 6 series antennas are recommended for big rig installations.

### Warning

*DO NOT* take the antenna through a high-pressure truck wash! Remove your antenna first... duh! Take advantage of our Giant Quick Disconnect.

## **Other vehicles**

For heavy truck or other special vehicle installation situations please contact us. We have installed our antennas on many specialized vehicles, and may have just the answer for you!

---

## Chapter 5. Operation

### Warning

You must always use caution with a long whip installed, as there will be many places in which your car will easily fit, however your antenna will *not*! Use a Whip Quick Disconnect and/or a fold-over!

### Initial tuneup

When shipped, the contactor is ordinarily set close to the top position of the coil housing. This is to give you some leeway when you first apply 12 volts to the motor.

Verify that you have wired the switch correctly, and that the contactor moves up and down when you move the switch up and down.

If you are using the *new* Hi-Q™ digital DC controller, the MFJ-1922 or the Ameritron SDC-100 controller:

1. Move the contactor all the way to the bottom.
2. Move the contactor up one or two coil turns.
3. Set this position as 000 on the digital read out.
4. Start to add your favorite frequencies.

As you move up in frequency, the contactor moves toward the top of the coil. Be sure to monitor its travel, at least until you get a good feel for where it loads the best. Higher frequency equals fewer coil windings, naturally.

The 80 meter position is usually about one inch from the bottom of the loading coil (except, of course, on the -5/160). Tune up the antenna on various bands until you are comfortable with it's use.

Any SWR below 1.5:1 is acceptable. We strongly recommend using the MFJ-909 at the radio end, not at the antenna end, to match the antenna impedance to the radio. If you cannot achieve a good SWR even with impedance matching, you probably have common mode current on your coax shield and or motor control wires. You will need to use ferrite chokes to suppress it. Please refer to the troubleshooting section for more information.

### Tip

A GREAT common mode current choke: coil up 8 or so turns of coax, approx. 5" diam. near the radio and tape it together.

### Tip

Some folks like to use colored electrical tape on the coil to mark the approximate contactor position for different bands.

### Tuning the antenna

Moving from band to band usually requires the largest movement of the contactor. Moving from 20 to 17 may require only a slight adjustment and the same from 17 to 15 and so forth.

Movement from one frequency to another within the band usually requires a slight “tweak” up or down. Remember, to move up in frequency, move the contactor up.

### **Warning**

Reasonable care must be given to impedance mismatch. Always observe your VSWR and/or power level. At any indication of a drastic change in either, STOP transmitting immediately. Although modern transceivers are designed to sense high VSWR, it is still prudent to monitor it while operating in any mode.

### **Warning**

DO NOT ATTEMPT TO TUNE UP THE ANTENNA WHILE DRIVING! Pull over first! You might save your life, and somebody else's too.

---

## Chapter 6. Troubleshooting

Our antennas are in constant use around the world. We are confident that it will work superbly on your vehicle as well. If you have a problem with any installation or use, please contact us. We have had years of experience and hundreds of installation histories to call on for your support. Be sure to read the support pages on the Hi-Q™ website.

### **Important**

Please do not call outside of working hours

### **Tip**

Good ohmic grounding and a good RF counterpoise will pay a good dividend.

## **Can't get a good match**

If you are experiencing trouble attaining a satisfactory VSWR, usually 1.5:1 or lower, you may have to use a variable inductor (0-15 $\mu$ H) or variable capacitor (100-1200 pF). This situation is not typical, and will certainly vary with the type and size of your vehicle. In some rare cases, a separate antenna tuner may be needed.

It is also a good idea to use ferrite chokes on the wires coming out of the antenna motor leads to suppress the common mode current. Wrap the wires around the core at least once. You may also put chokes on the coax cable. Toroids may also be used. This will eliminate the RF “pick-up” that may alter VSWR readings or affect the vehicle’s electronics. To prevent RF feed back on the motor lines you can add a pair of 100  $\mu$ H, 2 amp chokes CLOSE to the base of the antenna.

The NEW MFJ-910 or 909 HF Mobile Antenna Matcher does a good job on matching the antenna to the radios 52 ohm. A simple shunt coil will also do if properly wound and placed.

### **Tip**

Common mode current may be evident by *not* being able to get low VSWR. Use *as many* toroid cores and clip-on Ferrites as possible to alleviate the floating RF. Use the ferrites at *each* end of the coax cable and the motor wires.

### **Tip**

Every mobile installation is different, and no two vehicles have the same capacity effect on the antenna, so take time to install it properly and match it to 52 ohms.

## **Motor noise in receiver**

With each motor control lead make several turns around a ferrite clip-on choke or toroid core. These chokes should be as close to the base of the antenna and to the radio as possible.

A .01 ceramic cap to from the motor terminals to ground may also help to eliminate the motor noise.

If necessary, a pair of 100 $\mu$ H, 2 amp chokes may be installed in the motor leads as close to the base of the antenna as possible.



---

## Chapter 7. Care and Feeding

### Important

Please read announcements on the HI-Q™ website's SUPPORT often.

### Keep the coil clean!

#### Warning

Damage from arcing due to road grime is NOT covered by your warranty! Keep your antenna *clean*! Road grime can be conductive and cause arcing. Clean the coil with Rain-X™ at regular intervals.

We have measured on a "LIGHTNING" hit coil where the DIRTY side was as low as 220 OHMS!!! The dirt has give a PATH for the high voltage to travel down to the TUNED frequency (i.e.: where the CONTACTOR was located). At 500 watts the voltage is OVER 10,000 volts!!! At a kW is 23,000 V. REDUCE the power when weather is winter like, slushy salted roads and foggy. Protect your investment. NOTE: We have given this WARNING for the past two years we shall NOT Replace the coil free any more! The coil assembly. Replacement is \$250.00, no charge for the labour.

Special Note: Protect your investment keep your antenna clean. Avoid excessively dirty, grimy or salty environments. Use a good quality auto wax or RAIN-X on the coil housing and on the nickel-plated and powder coated parts. This will insure years of trouble free service. We will NO LONGER replace the coil for free. Cost is \$250.00 Protect your investment: KEEP IT CLEAN!, run lower power when dirty.

### Periodic Maintenance

Tighten the screws on the antenna occasionally.

---

## Chapter 8. Hi-Q™ Antenna Guarantee

The Hi-Q™ Series of antennas are unconditionally guaranteed for quality and workmanship for one year. If for any reason your Hi-Q™ antenna fails to perform due to quality or workmanship, other than damage due to negligence, improper usage or unauthorized disassembly, HI-Q™ Antennas will, at our discretion, repair or replace it at no charge, for one year from the date of purchase.

HI-Q™ antennas may be returned for a full refund within 14 days of purchase, if you feel that it was misrepresented in any way.

### **Warning**

Damage from arcing due to road grime is NOT covered by your warranty! Keep your antenna *clean!* Road grime can be conductive and cause arcing. Clean the coil with Rain-X™ at regular intervals.

If you find that the antenna does not meet the advertised specifications or for any other reason you are dissatisfied with the antenna, you may within fourteen (14) days of the original date of purchase return your antenna for a full refund, less shipping and handling. Refunds will be processed only after it has been determined that the antenna has not been altered, disassembled or damaged in any way.

Subsequent owners may, with our pre-approval, return an antenna for repair. *At our sole discretion*, we will either repair or replace the antenna. Please contact HI-Q™ before attempting to service your antenna. If we feel that field repair is appropriate or possible for you, we may authorize and instruct you in the correct procedures. Any unauthorized disassembly or negligent damage will void all guarantees written or implied.

Please call us before sending an antenna back to the factory for any reason. A returned material authorization (RMA) is necessary before warranty work will be performed. Shipping and handling in both directions will be at your expense.

### **Important**

You must receive prior approval and an RMA number before returning any Hi-Q™ product for repair or refund.

---

## Chapter 9. Contact Info

Hi-Q Antennas™

21085 Cielo Vista Way  
Wildomar, Ca. 92595

Web: <http://www.hiqantennas.com>

E-Mail: <sales@hiqantennas.com>

Phone: 951-674-4862

Fax: 951-245-2031

Open from 8 AM to 5 PM Monday through Friday.

### **Important**

Please do not call outside of working hours

Best 73!

Charles M. Gyenes W6HIQ, (VE7BOC/W6, HA5CMG)

---

## Appendix A. Tune-A-Dipole Instructions

The Hi-Q-TAD (Tune-A-Dipole) consists of a pair of one of the following Hi-Q™ HF Mobile antenna:

- Hi-Q™ 2.5/80
- Hi-Q™ 3/80
- Hi-Q™ 4/80
- Hi-Q™ 5/80
- Hi-Q™ 5/160

In normal use, the motors on the two antennas are wired in parallel, and the contactors will travel in parallel. Before the first use it is important to align the contactors on both antennas to the same spot.

If you are using a turns counting antenna controller, like the MFJ-1922, connect it to the pulse output of one antenna only. If you have two controllers, then you may connect one to each antenna.

A note on NVIS propagation:

Near Vertical Incidence Skywave, or NVIS, is a propagation mode that provides a reliable communications radius of 300-400 miles, regardless of obstructions like mountains. It works best when both the TX and RX antennas are mounted low to the ground. This provides very high gain in a straight-up lobe. It works from 160m to 20m, although 40m and 80m work best. D-layer absorption is insignificant, because such high angle signals spend much less time in the D-layer than a low angle signal would. At night, the MUF rarely falls below 7 MHz. So NVIS works all the time.

In my testing of the TAD, I have noticed *zero* S-units in received signal strength vs. a fullsize dipole at 80'. The dipole however had a noise level of S-6. Low noise is one of the reasons why you want to have an NVIS antenna for rag chewing with your friends in the 300-400 mile radius. The technique of small dipoles close to the ground for NVIS has been in use since WWII.

To utilize NVIS, simply mount your TAD 2-15 feet above ground, on a tripod for example.

1. Provide 12VDC from a 3 amp minimum power supply
2. Apply 12V to antenna 1, lower contactor until it is 1 turn from the bottom of the coil housing.
3. Repeat on antenna 2.
4. Connect motor wires in parallel.
5. Operate motors and verify that the contactors travel together.
6. Attach antennas to mounting bracket. Attach coax center conductor to one of the antenna feedpoints. Attach coax ground to the other antennas feedpoint and to the mounting bracket ground lug.
7. Attach mounting bracket to mast. Antennas should be pointing up slightly, in a "V" shape, not drooping low to the ground.

## Warning

If you use the TAD in a vertical configuration, you must use a non-conductive mast.

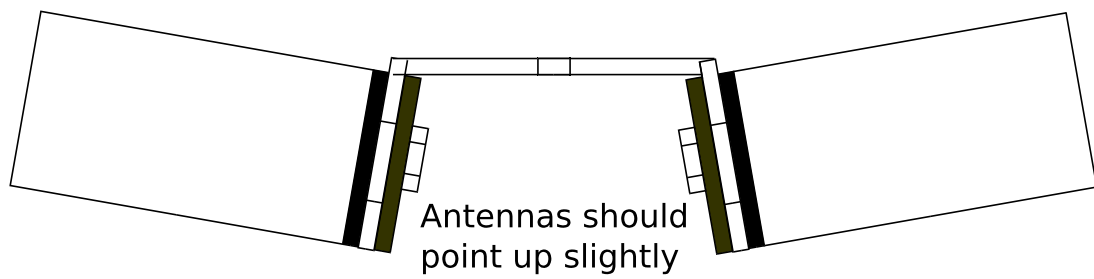
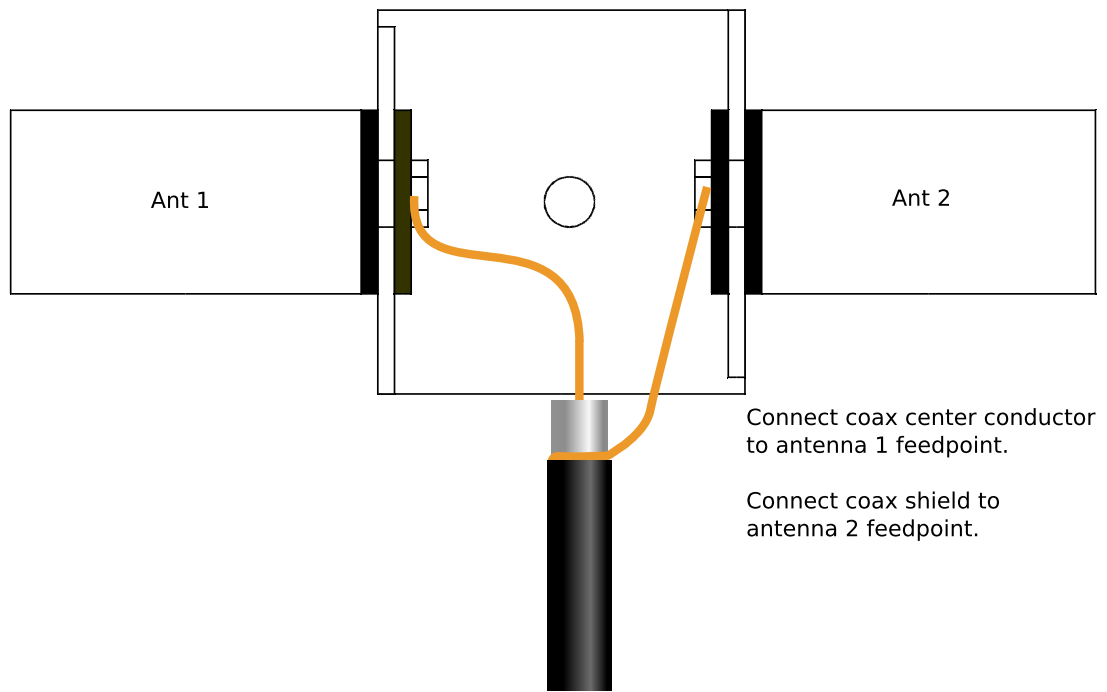

---

## Appendix B. Photo Gallery



Hi-Q™ Military NVIS Antenna Coupler



Hi-Q™ Military NVIS Antenna



Hi-Q™ Military Antenna in use by the US Marine Corps in Iraq



Hi-Q™ Fold-over base at 30 degrees





Hi-Q™ Fold-over base at 90 degrees



Hi-Q™ Submarine Antenna



The *new* Hi-Q™-6/2-30 MC-3H HF Mobile antenna.



The Hi-Q™-2.5/80 NVIS in combat in IRAQ.



Hi-Q™ antenna in Iraq.



Hi-Q™ on a Hummer.